

# Utility Switching



## Energetix Pnu Power - Standby power for utility power protection circuits

**Energetix Pnu Power has developed a pneumatic battery especially designed for the specific needs of the utility industries circuit breaker and protection relay applications in the transmission and distribution industries**

Instantaneous power is delivered via a unique system of power delivery that is supported by a patented technology

The product is focused on delivering high quality power to protect critical loads and maintain operational performance. The nature of the system, incorporating proven established components, along with compressed air as the energy storage medium, means that the system performs with consistent output quality for the whole discharge period.

Furthermore, the reliability of the system is not compromised by temperatures between  $-4^{\circ}\text{F}$  ( $-20^{\circ}\text{C}$ ) and  $+104^{\circ}\text{F}$  ( $+40^{\circ}\text{C}$ ) irrespective of the load profile\*. This eliminates the need for expensive environment control systems. The system can provide back up power for long periods - days if required - with scaleable energy storage to meet all application needs.

The known level of stored energy - which can be monitored locally or remotely - provides ultra high levels of operational confidence.

\*based upon cylinder exchange regime



[pnupower@energetixgroup.com](mailto:pnupower@energetixgroup.com) to contact us  
[www.energetixgroup.com](http://www.energetixgroup.com) to find out more

# Utility Switching

Creating the future of energy technology  
Product Characteristics Utility Switching unit



PRODUCT CHARACTERISTICS		DC1	DC2	DC4
OUTPUT	Maximum Power continuous	1kW	2kW	4kW
	Voltage DC nominal	12/24/48/54/110/120 or any combination for multiple voltage output		
	Programmable Voltage range	-10 to +15% of nominal		
	Current limit Ad.c.	84/42/21/9	168/84/42/18	336/168/84/36
	Noise Ripple Current Limit @ xxV	300mV pk-pk		
	Voltage regulation	+/- 0.4%		
INPUT STANDBY	Typical load draw from DC bus	~20W	~25W	~30W
INPUT RUNNING	Fuel	Industrial Compressed Air (-46°C dew point)		
	Supply Pressure PSI (bar)	75 (5)	132 (9)	308 (21)
	Consumption at full power scfm	32.0	57.6	46.2
	Storage	Configured for application. Steel, aluminum or composite cylinders. Installation can be indoor, outdoor or buried. see Energy Storage Brochure		
	Recharge (various methods designed to fit application and logistic requirements.)	1) Compressor: onsite, depot or portable. 2) Pressure bumping from portable reservoir 3) Cylinder pack exchange (can also be used as emergency backup)		
ENVIRONMENT	Ambient Temperature °F (°C)	indoor/outdoor conditions -4 (-20) to 104 (40)		
	Relative Humidity	5% to 95% non-condensing		
PHYSICAL	Dimensions*, power conversion module	1150mm (H) x 1100mm (W) x 705mm (D)		
	Mounting	Floor Mounted - IP56		
	Weight lbs (kg)	209 (95)	231 (105)	275 (125)
SAFETY	Certifications	CE commencing		
EMISSIONS	Cool Air btu/s (kW)	0.95 (1kW)	1.9 (2kW)	3.8 (4kW)
	Audible Noise	< 75 dBA @ 1m @rated output		
USER INTERFACE & MONITORING	Front Panel LCD Display	operating status, run time (UPS), run time (standby), operating voltage and power		
	Graphical User Interface	full logging including high speed logging, reservoir pressures, operating pressures, full diagnostic capability and parameter access		
COMMUNICATIONS	Local	RS-232C and USB Included		
	Remote	GSM or GPRS Modem and Ethernet/IP Optional		
ALARMS	Form C Dry Contacts	2 alarms customers configurable		
	Visual	DC OK (green), DC Fail (red), AC OK (green), System Fault (red), Low Energy (yellow)		
	Custom	Configured to customer request and specifications		

\* Dimensions do not include energy Air storage.

## Performance Benefits

- High reliability
- Performs in harsh operational environments
- No cycle restrictions
- Reduces generator starts
- Run time/time remaining accuracy
- No power degradation throughout lifetime
- Saves 20% to 30% rectifier capacity
- Reduces network and cabling cost
- N+1 and 2N configuration
- Very low maintenance

## Operating Flexibility

- Scalable power and run time (n+1 capability)
- Provides cooling during runtime
- Wide range of operating temperatures
- Easily installed

## Environmentally Friendly

- Lead acid free energy storage solution
- No hazardous disposal issues
- Low recycling costs

## Remote GUI for System Control Schematic

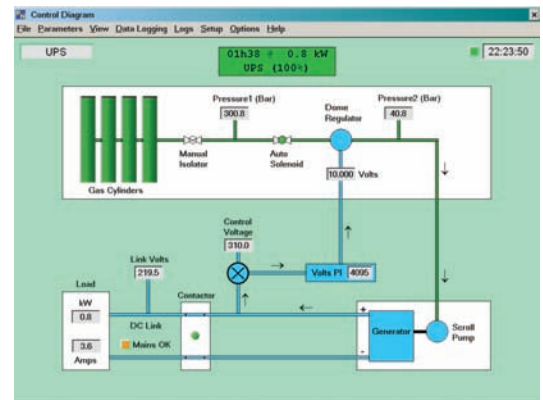

Energetix Pnu Power -  
North American contacts:

John.tiberio@energetixgroup.com  
Tel: 954 675 3434  
Ian.glease@energetixgroup.com  
Tel: 954 328 1006

Energetix Pnu Power - European Headquarters,  
Capenhurst Technology Park, Capenhurst,  
Chester. CH1 6EH Tel +44 (0)151 348 2100  
Fax +44 (0)348 2101 www.energetixgroup.com